

Merk:	KLAAS
Type:	K1003RSX

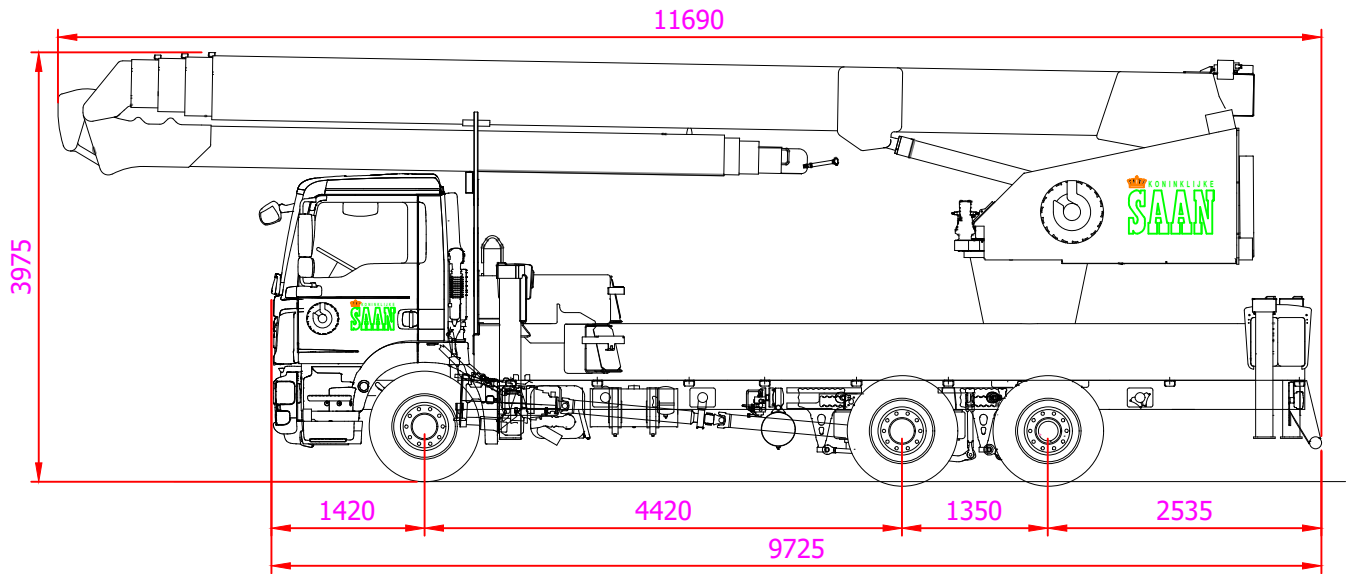

Voertuigeigenschappen

Totaal gewicht (kg)	Asconfiguratie	Hondengang mogelijk	Kraanvoeding	Doorrijhoogte
21000	6x2x4	Nee	32A	397,5



KONINKLIJKE
SAAN

0900 - 660 60 60
www.saan.nl
info@saan.nl

Versiedatum: 23-8-2021

Servicecode:

KALUKR

This publication remains the property of the publisher and shall be treated as confidential, unless contractually specified otherwise. No parts of it may be reproduced, stored in a retrieval system or transmitted in any form or by any means, without the prior written permissions of the publisher. Typing errors reserved. No rights may be derived from these drawings and tables.

Pagina:

1 / 4

Copyright Koninklijke Saan B.V. 2009

Merk:	KLAAS
Type:	K1003RSX

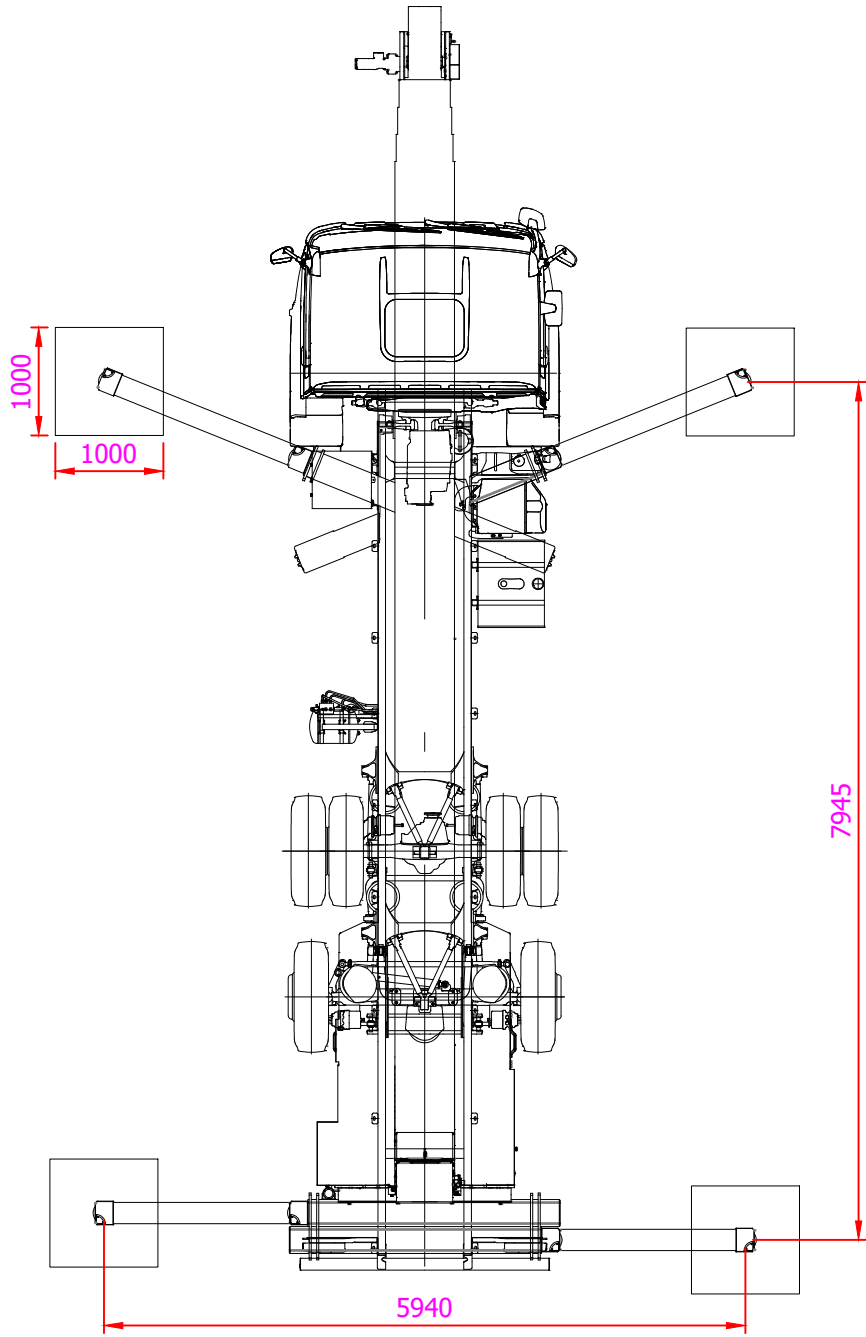

KONINKLIJKE
SAAN

0900 - 660 60 60
www.saan.nl
info@saan.nl

Versiedatum: 23-8-2021

Servicecode:

KALUKR

This publication remains the property of the publisher and shall be treated as confidential, unless contractually specified otherwise. No parts of it may be reproduced, stored in a retrieval system or transmitted in any form or by any means, without the prior written permissions of the publisher. Typing errors reserved. No rights may be derived from these drawings and tables.

Pagina:

2 / 4

Copyright Koninklijke Saan B.V. 2009

Merk:	KLAAS
Type:	K1003RSX

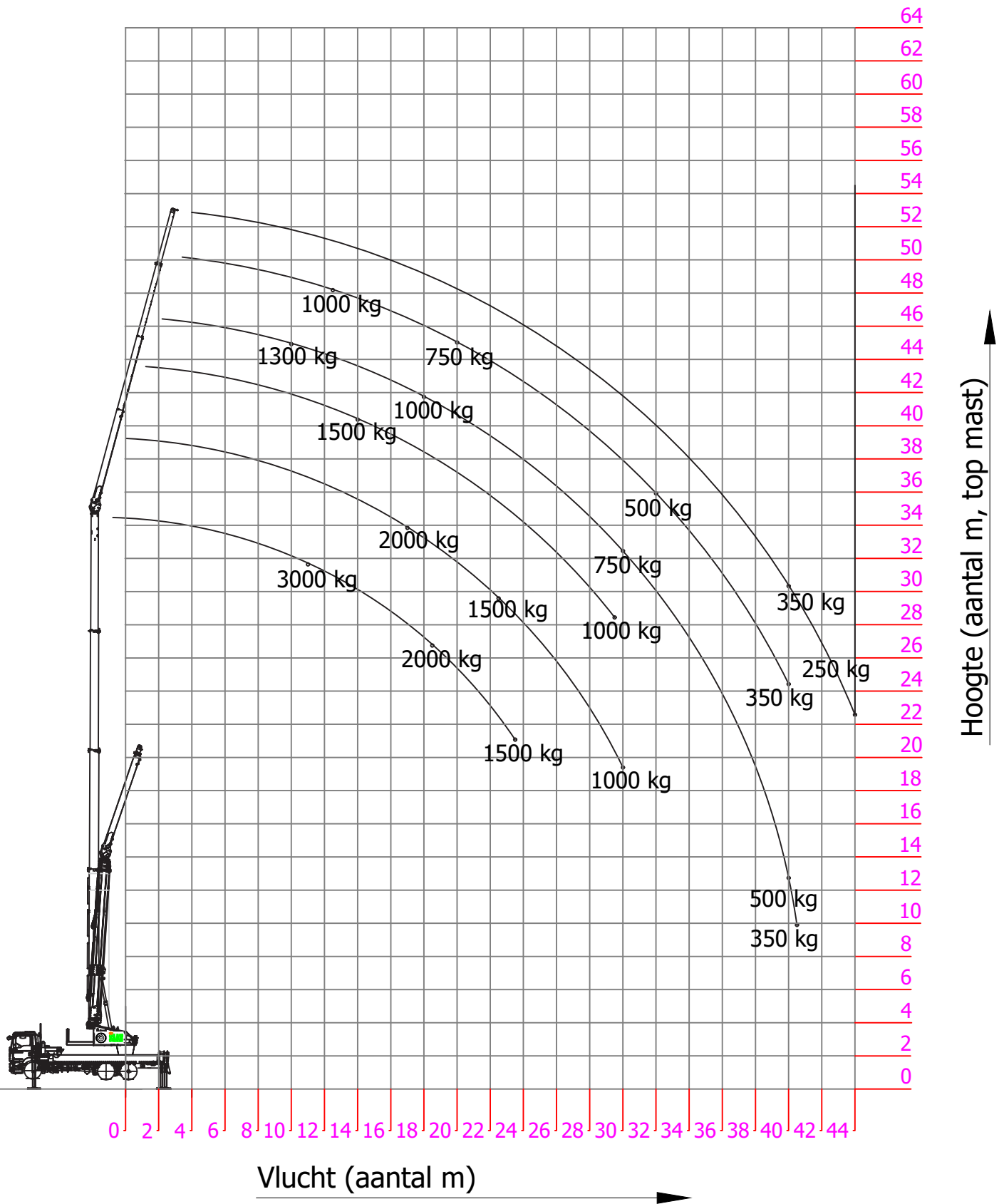

KONINKLIJKE
SAAN

0900 - 660 60 60
www.saan.nl
info@saan.nl

Versiedatum: 23-8-2021

Servicecode:

KALUKR

This publication remains the property of the publisher and shall be treated as confidential, unless contractually specified otherwise. No parts of it may be reproduced, stored in a retrieval system or transmitted in any form or by any means, without the prior written permissions of the publisher. Typing errors reserved. No rights may be derived from these drawings and tables.

Pagina:

3 / 4

Copyright Koninklijke Saan B.V. 2009

Merk:	KLAAS
Type:	K1003RSX

