

Merk:	DAF/HIAB
Type:	CF 400 FAN/XS 377

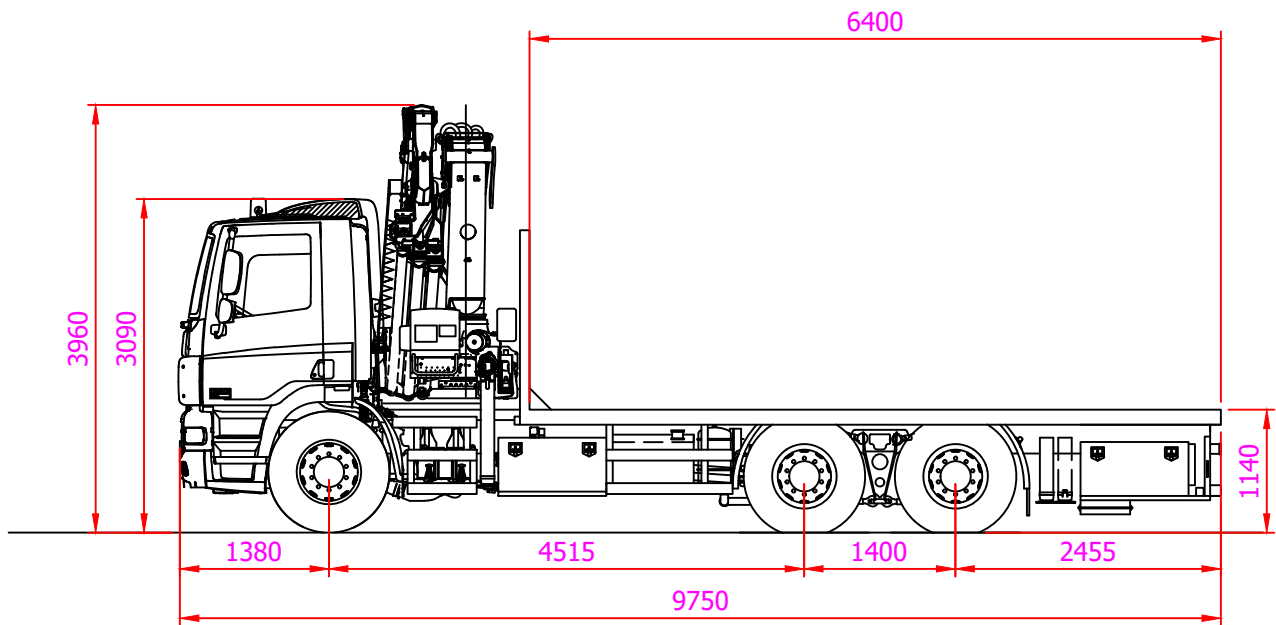

Voertuiginformatie		
Leeggewicht voertuig	16225	kg
Max. massa voertuig	28000	kg
Totale lengte	9750	mm
Breedte	2550	mm
Doorrijhoogte	3920	mm



KONINKLIJKE
SAAN

0900 - 660 60 60
www.saan.nl
info@saan.nl

Versiedatum: 8-8-2022

Servicecode:

IB37

This publication remains the property of the publisher and shall be treated as confidential, unless contractually specified otherwise. No parts of it may be reproduced, stored in a retrieval system or transmitted in any form or by any means, without the prior written permissions of the publisher. Typing errors reserved. No rights may be derived from these drawings and tables.

Pagina:

1 / 4

Copyright Koninklijke Saan B.V. 2009

Merk:	DAF/HIAB
Type:	CF 400 FAN/XS 377

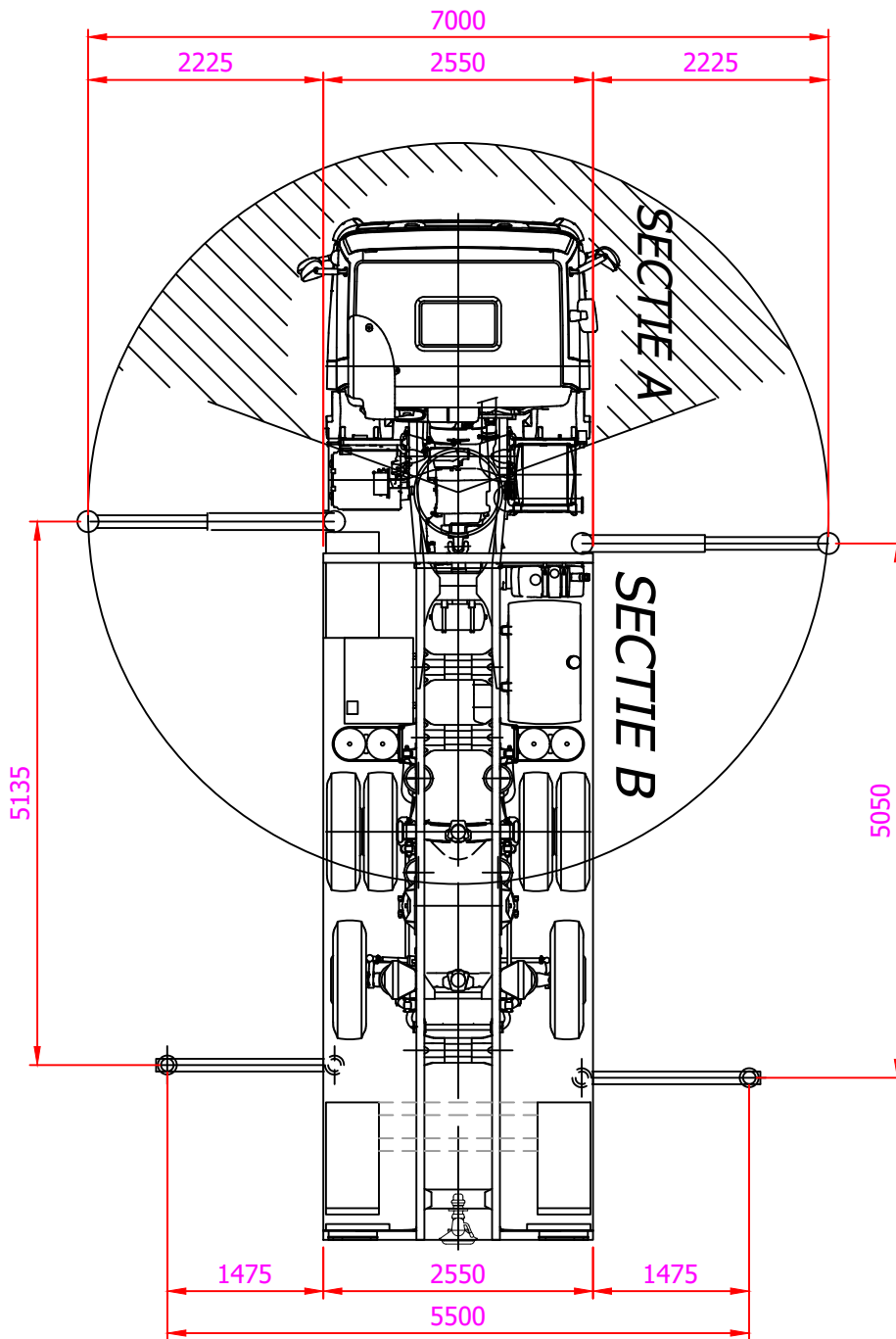

Let op! Zwenkbereik kraan is 420 graden!



KONINKLIJKE
SAAN

0900 - 660 60 60
www.saan.nl
info@saan.nl

Versiedatum: 8-8-2022

Servicecode:

IB37

This publication remains the property of the publisher and shall be treated as confidential, unless contractually specified otherwise. No parts of it may be reproduced, stored in a retrieval system or transmitted in any form or by any means, without the prior written permissions of the publisher. Typing errors reserved. No rights may be derived from these drawings and tables.

Pagina:

2 / 4

Copyright Koninklijke Saan B.V. 2009

Merk: DAF/HIAB
 Type: CF 400 FAN/XS 377

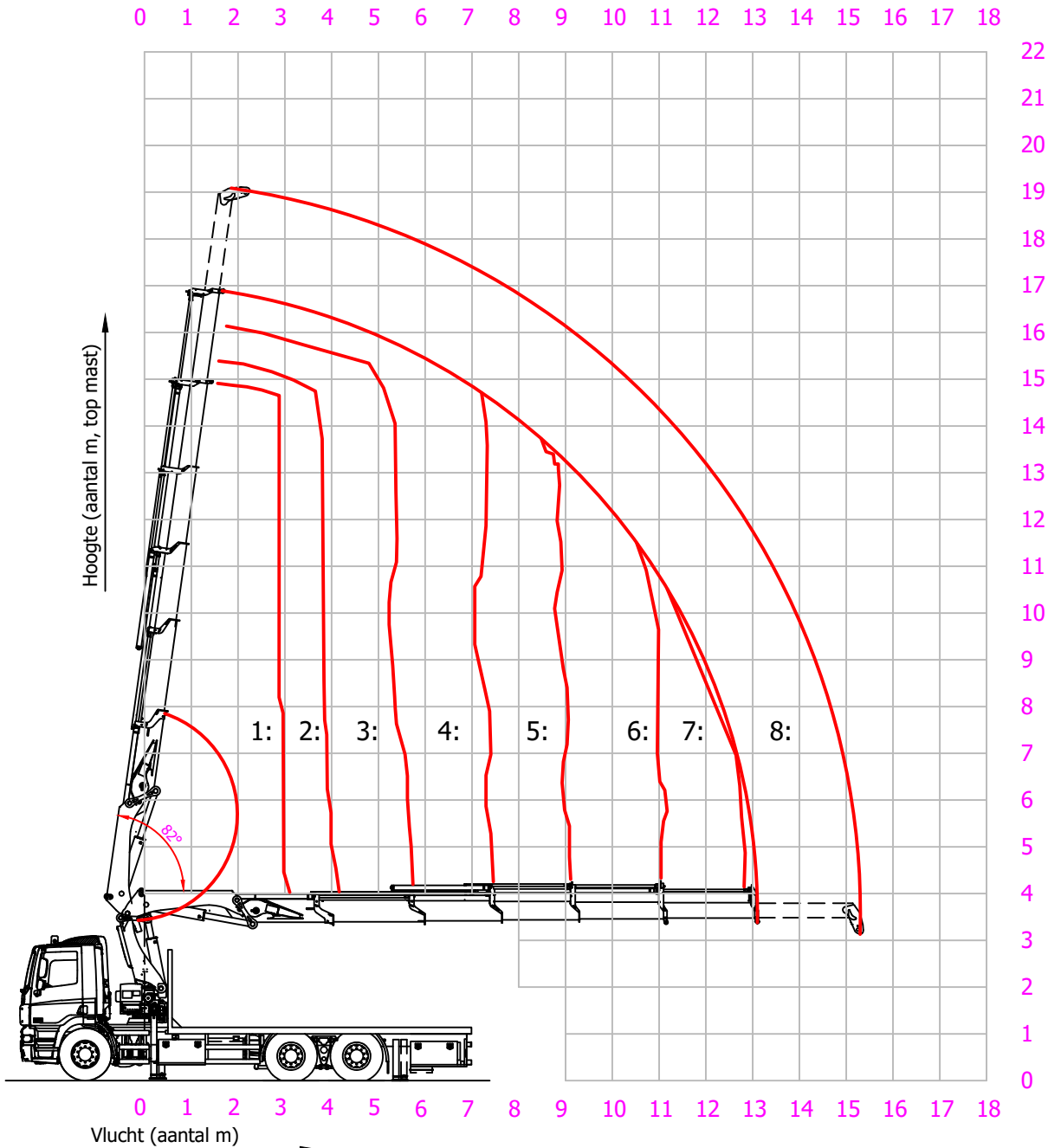

Hefcapaciteit bij een vlucht van:

Sectie A (in Kg)		Sectie B (in Kg)		Vlucht in M.
Incl. Mech. deel	Excl. Mech. deel	Incl. Mech. deel	Excl. Mech. deel	
8750 *	8860	1: 9880 *	10000	3.1
6810 *	6880	2: 7725 *	7800	4.3
4660 *	4725	3: 5330 *	5400	6.0
3400 *	3475	4: 3920 *	4000	7.8
2640 *	2725	5: 3070 *	3150	9.6
2110 *	2200	6: 2470 *	2560	11.6
1750 *	1840	7: 2050 *	2140	13.7
1480		8: 1740		16.0 (mech.)

* Met mechanisch deel IN



KONINKLIJKE
SAAN

0900 - 660 60 60
 www.saan.nl
 info@saan.nl

Versiedatum: 8-8-2022

Servicecode: IB37

This publication remains the property of the publisher and shall be treated as confidential, unless contractually specified otherwise. No parts of it may be reproduced, stored in a retrieval system or transmitted in any form or by any means, without the prior written permissions of the publisher. Typing errors reserved. No rights may be derived from these drawings and tables.

Pagina:
 3 / 4

Copyright Koninklijke Saan B.V. 2009

Merk: DAF/HIAB
 Type: CF 400 FAN/XS 377

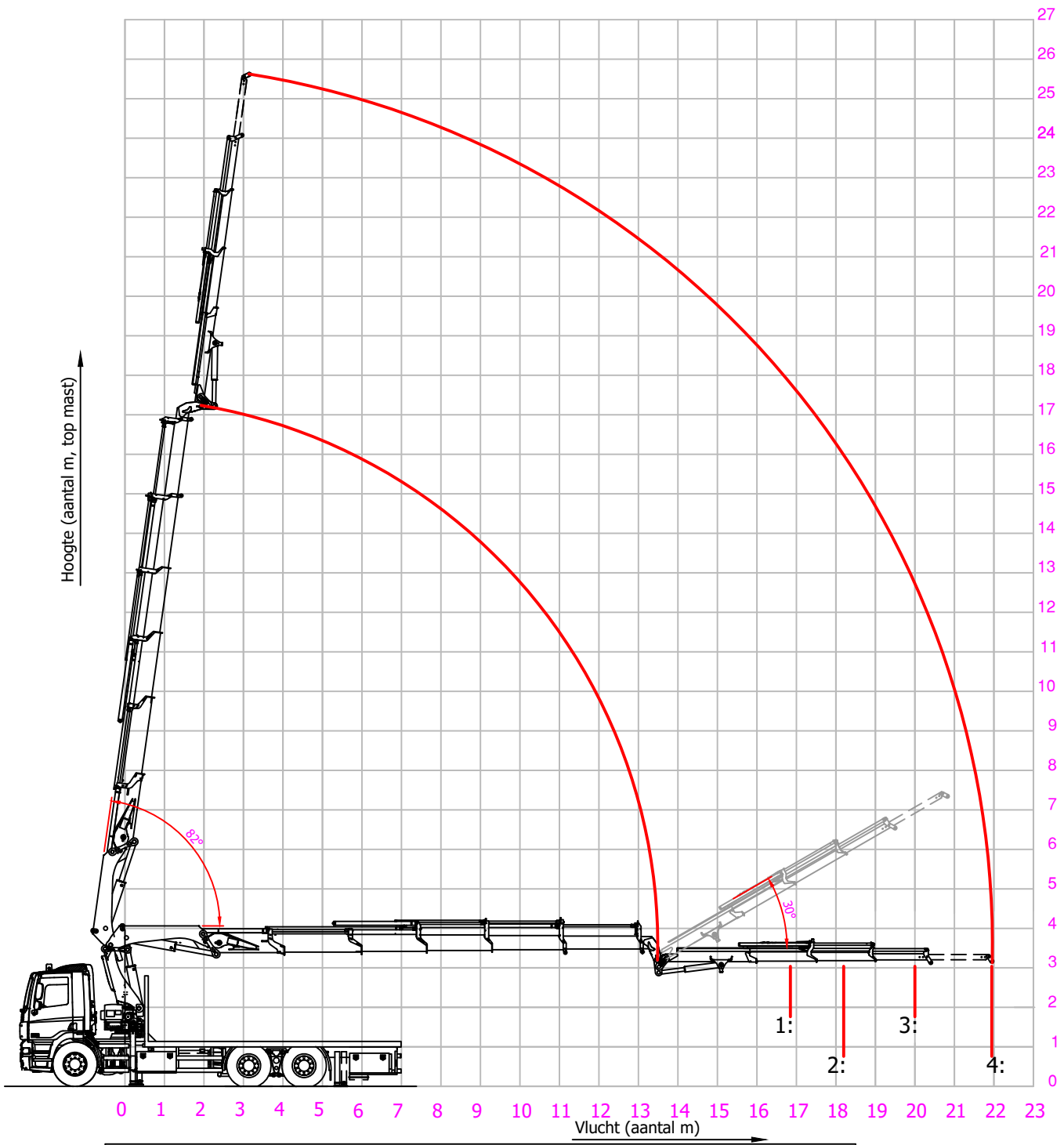

Hefcapaciteit bij een vlucht van:

Sectie A (in Kg)	Sectie B (in Kg)		Vlucht in M.
420	1:	1120	16.8
360	2:	1020	18.3
320	3:	920	20.0
300	4:	840	21.8

Eigen gewicht Jib = 680 kg

LET OP: Capaciteit jib wordt lager bij omhoog gerichte jib onder hoek max. 30 graden



KONINKLIJKE
SAAN

0900 - 660 60 60
 www.saan.nl
 info@saan.nl

Versiedatum: 8-8-2022 Servicecode: IB37

This publication remains the property of the publisher and shall be treated as confidential, unless contractually specified otherwise. No parts of it may be reproduced, stored in a retrieval system or transmitted in any form or by any means, without the prior written permissions of the publisher. Typing errors reserved. No rights may be derived from these drawings and tables.
 Copyright Koninklijke Saan B.V. 2009

Pagina:
 4 / 4